

# IOT ENABLE HEALTHCARE APPLICATION FOR DIABETIC PATIENT

P. Parthasarathi  
Assistant Professor

Aswani Soman  
UG Scholar

S. Karthikmani  
UG Scholar

M. Lavanya  
UG Scholar

R.Thiruvikramanarayana  
Sharma  
UG Scholar

Department of Computer Science and Engineering,  
Akshaya College of Engineering and Technology,  
Coimbatore, TamilNadu, India

**Abstract** – Generally every patient have unique login to update and track their health reports. Doctors prefer diet control and tablets to control the diabetics. If diabetics are uncontrollable doctor prefer walking shoes. These shoes have GPS tracker and integrated chip, which count the steps, taken by the patient. (i.e.) for example 5steps is approximately 1Km. Using the step count, patient's blood sugar level checked and maintained. Patient step can be graphically represented and stored in the cloud and the doctor can view the reports. With the report doctor can easily identify the blood sugar level. If step count is higher, sugar level become low. GPS tracker help in location tracking as a result accurate data of patients is stored in the cloud and evaluated the result is sent to the patients and also to the doctor using short message services.

**Keywords** — Internet of Things, Controller, Web Blocks, GPS, FP Growth

## I. INTRODUCTION

IOT (Internet of things) is the inter-networking of physical devices, vehicles, buildings, and other items are embedded with electronics, software, sensors, actuators, and network connectivity that enable these objects to collect and exchange data. IOT also allows objects to be sensed or controlled remotely across existing network infrastructure creating integration of the physical world into computer-based systems, and resulting in improved efficiency, accuracy and economic benefit in addition to reduced human intervention. IOT offer advanced connectivity of devices, systems, and services that goes beyond machine-to-machine (M2M) communications and covers a variety of protocols, domains, and applications [1][2].

The vision of the Internet of things has evolved due to a convergence of multiple technologies, including ubiquitous wireless communication, real-time analytics, machine learning, commodity sensors, and embedded systems. This means that the traditional fields of embedded systems, wireless sensor networks, control systems, automation (including home and building automation), and others all contribute to enabling the Internet of things (IoT).

The concept of the Internet of things became popular in 1999, through the Auto-ID Centre at MIT and related market-analysis publications [3]. Radio-frequency identification (RFID) was seen by Kevin Ashton (one of the founders of the original Auto-ID Centre) as a prerequisite for the Internet of things at that point. Ashton prefers the phrase "Internet for

Things." If all objects and people in daily life were equipped with identifiers, computers could manage and inventory them.

## II. RELATED WORK

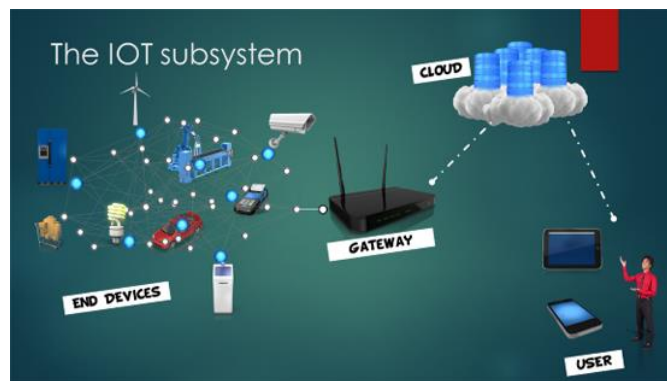

Fig 1: Structure of Subsystem

### 2.1 Working of IoT

IoT is a technology concept; it is an aggregation of already available technologies. Similar to the way in which Internet communicate and connecting humans through WWW, IoT aims to take this connectivity [4] to next level by connecting various devices to the internet facilitating human-machine, machine-machine interactions also. IoT ecosystem has business applications in areas of Home Automation, Automotive, Factory assembly line automation, Retail, Medical/Preventive healthcare and more.

### 2.2 Characteristics of IoT

Each characteristic encompasses of a set of capabilities depending on tradeoffs and decisions on it.

#### Intelligence

Considering computer (i.e. software & hardware) provide the “intelligent spark” that makes a product experience smart. It experience distributes compute tasks between a smart phone and the cloud.

#### Connectivity

Connectivity in the IoT is an important thing. It enables network accessibility and compatibility [5]. Accessibility refers to access on a network while compatibility refers the common ability.

#### Expressing

It enables interactivity with people and the physical world. It also provides us to create products that interact intelligently

with the real world. It allows direct interaction with people and the environment.

### Energy

Energy plays a vital role in creations to life. Energy harvesting, power efficiency, and charging infrastructures are necessary part a power intelligent ecosystem that we must design.

## III. PROPOSED WORK

The proposed system we are introducing new technology for diabetic patient to reduce their sugar level. We are also providing a secure data base to the doctor and patient. The patient details will be updated to the doctor based on their daily performance [6][7]. In this we can predict the dangerous changes in the blood sugar.

Also we include the dosage information and also the insulin taken by the patients, which are provided by the doctors to the patients. These people are mainly maintained the database and all other information about the patients and all other relevant data. In this we can identify whether the patients having either hyperglycaemia or hypoglycaemia condition.

Therefore, in the present system need to produce a personal healthcare database. A personal healthcare database consist of more factors such as the dosage of insulin content, the step count, the location of the patients and other relevant data. This solution has been evaluated by multi dispensary group formed by patients, doctors, nurses and the patient's relatives.

### Advantages of Proposed Work

- The system can store large amount of data at a time.
- Since the data are stored in the cloud database we can easily get larger storage space.
- The authentication process is very high, so it will increase the security level
- The connectivity model took less time to complete the authentication and encryption operations.

### Problem Statement

The main drawbacks that are related to the present existing system will help us to create our project and the new ideas for our project. The main drawbacks of this system are as follows

- It will not provide any security system for the patient documents.
- It will not consider the main fault and the privacy policies related to the patients.
- These methods not provide the exact progress of the patients and it should not provide the updated information about the patients.
- The connectivity model took long time to complete the updating process

### Module Description

#### Configuring IOT Controller

Clock pulse generating switch is embedded in shoes. It will generate clock pulse for every steps. Clock pulse is counted using counter.

#### Setting up web blocks

We create a web Page. The step count details upload by the help of IOT Controller. The details are updated to the doctor.

#### Diagnosis of step counts

The doctor will access the data. Identify what are the steps to be followed after the doctor will give the report to the user.

#### GPS Support system

In this we are including GPS system to monitor the patient's location and each and every moment updated to the family members.

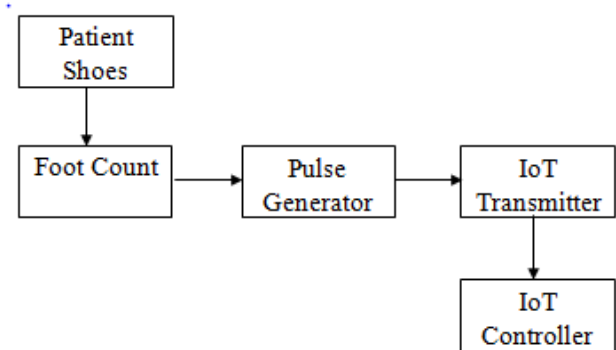

Fig 2: Configuring IOT Controller

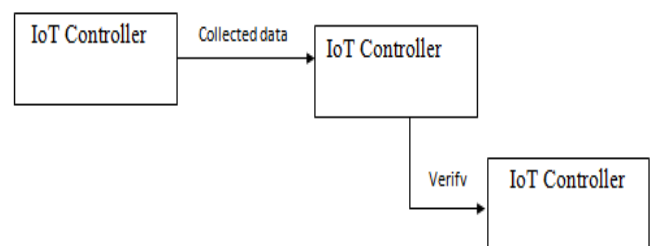

Fig 3: Setting up web blocks

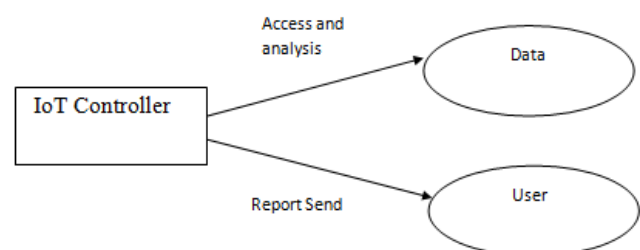

Fig 4 : Diagnosis of step counts

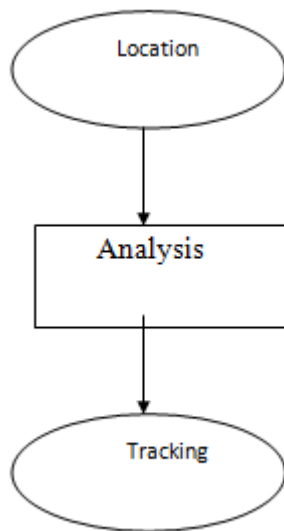

Fig 5: GPS Support system

- [4] <http://www.hhs.gov/ocr/privacy/hipaa/administrative/privacyrule/index.html>.
- [5] Agreement scheme preserving user anonymity in global mobile networks,” *Wireless Personal Communications*, DOI: 10.1007/s11277-015-2344-z, 2015.
- [6] Gope, T. Hwang, “Lightweight and Energy Efficient Mutual Authentication and Key Agreement Scheme with User Anonymity for Secure Communication in Global Mobility Networks,” *IEEE Systems Journal*, DOI: 10.1109/JSYST.2015.2416396, 2015.
- [7] T. Hwang, P. Gope, “IAR-CTR and IAR-CFB: Integrity Aware Real-time Based Counter and Cipher Feedback Modes,” *Security and Communication Networks (Wiley Journal)*, DOI: 10.1002/sec.1312,2015.

### Energy Conversion

In this we are mainly deals with the conversion of energy. We also knows that “Energy can neither be produced or be destroyed, but it can transfer from one to the other form” same method is followed here is that, here we get kinetic energy while moving the person from one place to the other and this energy (kinetic energy) can be changed by electrical energy to boost up the battery or the power bank.

## IV. CONCLUSION

In this project has provided as an excellent opportunity and experience to use and share our knowledge. We gained a lot of practical knowledge regarding, planning, purchasing and marketing while doing this project work. We feel the project work is a good solution to many patients and also the doctor can monitor the current status of the patients continuously and it provide a good result and also avoid the problem that are faced by the diabetic patients. We are proud, that we have completed the work within the limited time based successfully. We are capable of understanding the difficulties while conducting those process and related task on it. We are also decided to do best skill making the project the best by the suitable facilities.

### References

- [1] P. Gope, T. Hwang, “A Realistic Lightweight Authentication Protocol Preserving Strong Anonymity for Securing RFID System,” *Computers& Security (Elsevier Journal)*, Vol. 55, pp. 271–280, 2015.
- [2] R. K. Palvannan and K. L. Teow “Queuing for Healthcare,” *J. Med. Syst.*, vol. 36, no. 2, pp. 541–547, Apr. 2012
- [3] P. Gope, T. Hwang, “Untraceable Sensor Movement in DistributedIoT Infrastructure,” *IEEE Sensors Journal*, Vol. 15 (9), pp. 5340 – 5348, 2015.